

May 26, 2010

Memorandum To: All coaches and teams participating in the May 28-30, 2010  
MAYB Tournament in Bonner Springs, Kansas

From: Andy Price - pricea@usd204.net  
Clay Oakes – oakesc@usd204.net

Attached, you will find the schedule for your team's participation in the  
May 28-30 West KC Shootout in Bonner Springs, Kansas.

Please make sure you check in at the admission table upon arrival. We will have two  
complimentary coach's passes per team for you to pick up at the gate. Please show your  
pass each time you arrive at the gym for a game. All other assistant coaches and  
spectators will be required to purchase an admission ticket. Admission prices will be:

\$ 10 Adult Weekend Pass  
\$ 8 Student (K-12) Weekend Pass

|                            |                                 |
|----------------------------|---------------------------------|
| \$ 4 Adult – Friday only   | \$ 3 Student K-12 Friday only   |
| \$ 5 Adult – Saturday only | \$ 4 Student K-12 Saturday only |
| \$ 5 Adult – Sunday only   | \$ 4 Student K-12 Sunday only   |

All teams must provide either a scorekeeper or a clock operator for each of their games.  
Coaches and scorekeepers (or clock operators) should review the enclosed MAYB  
tournament rules prior to arriving at the tournament. Reviewing them prior to arrival will  
help us keep our games on schedule, and will minimize the possibility of confusion  
during the tournament. Maps for the gym locations and area attractions are also enclosed.

Concessions will be provided at all gyms and a full service concession stand with food  
and drinks District PE building. No outside food or drinks will be allowed inside any of  
the facilities (except for water).

Thanks in advance for your participation. We look forward to a great event for your  
athletes!

# **West KC Summer Shootout**

## **Bonner Springs, KS 66012**

### **REVISION 3**

Driving Directions: See Map on next page.

One of the main roads in Bonner Springs is under major construction. The portion of W Kump St (K-32) that is impassable is marked in red on the map below. To access any of the gyms you will need to take K-7 North or K-7 South into Bonner Springs. Take the Nettleton Ave exit and turn west. If you are playing at CMS, District PE, or BSHS, you will turn right on Morse Ave and Left on Bluegrass St. (marked in green).

If you are playing at BSE, you will want to take Nettleton Ave and turn right on Kindred. Kindred looks like an alley but you can pass through straight to the BSE gym. At the bottom of the hill you will stay straight on Shadyside St. and turn left into the gymnasium parking lot. Due to one-way roads, you will have to leave BSE slightly differently. When leaving BSE turn right on Shadyside St. and right on Neconi Ave. Take a left on 2<sup>nd</sup> St. and turn left again at Nettleton.

#### **CMS = Clark Middle School – 420 N. Bluegrass**

I-70 to K7 South, Right on Nettleton, Right on Morse, Left on Bluegrass. GREEN PATH

#### **District PE – 100 N. McDaniel**

I-70 to K7 South, Right on Nettleton, Right on Morse, Left on Bluegrass. GREEN PATH

#### **BSHS = Bonner Springs High School – 100 N. McDaniel**

I-70 to K7 South, Right on Nettleton, Right on Morse, Left on Bluegrass. GREEN PATH

#### **BSE = Bonner Springs Elementary – 212 S. Neconi**

I-70 to K7 South, Right on Nettleton, Right on Kump, Left on Neconi. GREEN/PURPLE PATH  
Use the BLUE path when leaving BSE

**Tournament Directors:** Andy Price – 913-915-2998, Clay Oakes – 913-636-4218



# West KC Summer Shootout Bonner Springs, KS 66012

**Tournament Director:** Andy Price – 913-915-2998, Clay Oakes – 913-636-4218

**CMS = Clark Middle School – 420 N. Bluegrass**

I-70 to K7 South, Right on Nettleton, Right on Morse, Left on Bluegrass.

**PEC – 100 N. McDaniel**

I-70 to K7 South, Right on Nettleton, Right on Morse, Left on Bluegrass.

**BSHS = Bonner Springs High School – 100 N. McDaniel**

I-70 to K7 South, Right on Nettleton, Right on Morse, Left on Bluegrass.

**CC = Bonner Springs Community Center – 200 E. Third**

I-70 to K7 South, Right on Nettleton, Left on Kump, Left on Third.

**BSE = Bonner Springs Elementary – 212 S. Neconi**

I-70 to K7 South, Right on Nettleton, Right on Kump, Left on Neconi.



## Area Attractions

1. Village West - Legends Shopping Center  
Kansas Speedway  
KC T-Bones Baseball Complex  
Great Wolf Lodge  
Nebraska Furniture Mart  
Cabelas
2. Sunflower Golf Course  
Wyandotte County Park  
Agriculture Hall of Fame  
Verizon Amphitheatre
3. Holiday Inn Express  
13031 Ridge Av.  
Bonner Springs, KS 66012



## West KC Shootout 5<sup>th</sup>-6<sup>th</sup> Grade Girls

4 games round robin and one bracket.  
Awards given for 1<sup>st</sup> and 2<sup>nd</sup> in bracket.

| Team                        | Wins | Losses | Seed |
|-----------------------------|------|--------|------|
| 1. The Lightning – KS       |      |        |      |
| 2. MO Valley Blazers        |      |        |      |
| 3. Gardner Blazers          |      |        |      |
| 4. Sabetha Silver Stars     |      |        |      |
| 5. Mound City Panthers - MO |      |        |      |

| Saturday | CMS                  | BSHS |
|----------|----------------------|------|
| 1:00     | -                    | 4-5  |
| 2:00     | -                    | 1-2  |
| 3:00     | -                    | 3-4  |
| 4:00     | 1-5                  | -    |
| 5:00     | 2-4                  | -    |
| 6:00     | 3-5                  | -    |
| 7:00     | -                    | -    |
| 8:00     | 2-3                  | -    |
| Sunday   | CMS                  | BSHS |
| 9:00     | -                    | 1-3  |
| 10:00    | -                    | 2-5  |
| 11:00    | -                    | 1-4  |
| 12:00    | -                    |      |
| 1:00     | -                    | G1   |
| 2:00     | -                    | -    |
| 3:00     | G2                   | G3   |
| 4:00     | -                    | -    |
| 5:00     | G4 – 1 <sup>st</sup> | -    |

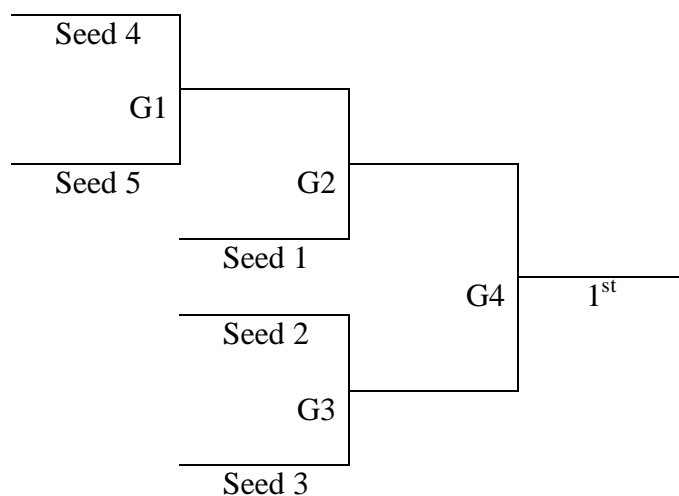

# 9<sup>th</sup> - 10<sup>th</sup> Grade Girls

4 games round robin and one bracket.  
Awards given for 1<sup>st</sup> and 2<sup>nd</sup> in bracket.

| Team                           | Wins | Losses | Place |
|--------------------------------|------|--------|-------|
| 1. Missouri Rage               |      |        |       |
| 2. Topeka Vikings              |      |        |       |
| 3. Gardner Blazers             |      |        |       |
| 4. Pinnacle Banks NE All Stars |      |        |       |
| 5. Bonner Springs              |      |        |       |

| Saturday | CMS                  | PEC |
|----------|----------------------|-----|
| 8:00     | 1-3                  | -   |
| 9:00     | -                    | -   |
| 10:00    | 1-4                  | -   |
| 11:00    | -                    | -   |
| 12:00    | 1-2                  | -   |
| 1:00     | -                    | -   |
| 2:00     | 3-4                  | -   |
| 3:00     | -                    | -   |
| 4:00     | -                    | 2-3 |
| 5:00     | -                    | -   |
| 6:00     | -                    | 4-5 |
| 7:00     | -                    | -   |
| 8:00     | -                    | 2-5 |
| Sunday   | CMS                  | PEC |
| 10:00    | -                    | 2-4 |
| 11:00    | 3-5                  | -   |
| 12:00    | 1-5                  | -   |
| 1:00     | -                    | -   |
| 2:00     | G1                   | -   |
| 3:00     | -                    | -   |
| 4:00     | G2                   | G3  |
| 5:00     | -                    | -   |
| 6:00     | G4 – 1 <sup>st</sup> | -   |

# 9<sup>th</sup> – 10<sup>th</sup> Grade Girls Bracket

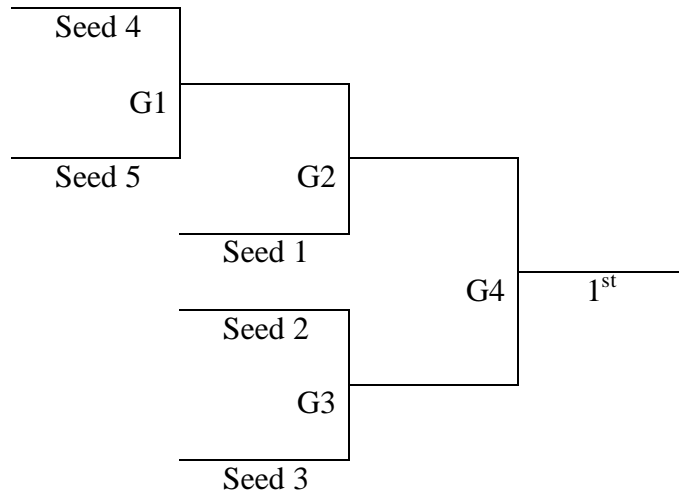

# 11<sup>th</sup> - 12<sup>th</sup> Grade Girls

4 games round robin and one bracket.  
Awards given for 1<sup>st</sup> and 2<sup>nd</sup> in bracket.

| <b>Team</b>                    | <b>Wins</b> | <b>Losses</b> | <b>Place</b> |
|--------------------------------|-------------|---------------|--------------|
| 1. Missouri Rage               |             |               |              |
| 2. MO Lady Sting               |             |               |              |
| 3. Kansas City Spirit          |             |               |              |
| 4. Pinnacle Banks NE All Stars |             |               |              |
| 5. Bonner Springs              |             |               |              |

| <b>Saturday</b> | <b>CMS</b> | <b>PEC</b> |
|-----------------|------------|------------|
| 8:00            | -          | -          |
| 9:00            | 1-3        | -          |
| 10:00           | -          | -          |
| 11:00           | 1-2        | -          |
| 12:00           | -          | -          |
| 1:00            | 1-4        | -          |
| 2:00            | -          | -          |
| 3:00            | 2-3        | -          |
| 4:00            | -          | -          |
| 5:00            | -          | 4-5        |
| 6:00            | -          | -          |
| 7:00            | 3-4        | 2-5        |
| 8:00            | -          | -          |
| 9:00            | -          | -          |
| <b>Sunday</b>   | <b>CMS</b> | <b>PEC</b> |
| 9:00            | 3-5        | 2-4        |
| 10:00           | 1-5        | -          |
| 11:00           | -          | -          |
| 12:00           | -          | G1         |
| 1:00            | G3         | -          |
| 2:00            | -          | G2         |
| 3:00            | -          | -          |
| 4:00            | -          | -          |
| 5:00            | -          | -          |
| 6:00            | -          | G4         |

# 11<sup>th</sup> – 12<sup>th</sup> Grade Girls Bracket

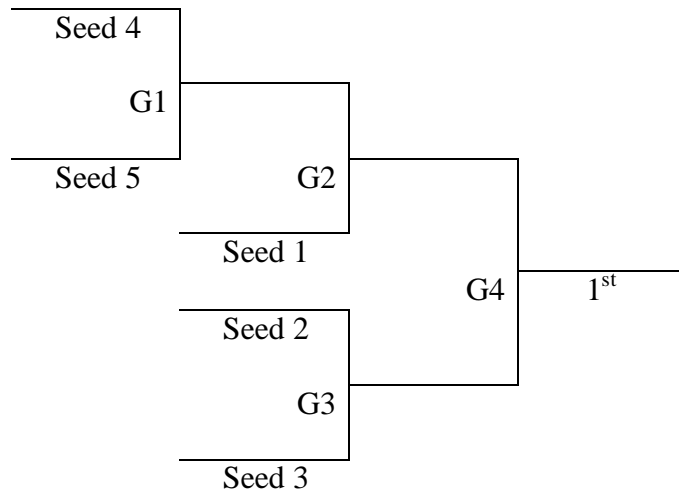

# 11<sup>th</sup> – 12<sup>th</sup> Grade Boys

Round robin pool play with top 2 teams in each pool going to bracket A and others to Bracket B.

Awards given to top 3 teams in bracket A and winner of bracket B.

| <b>Pool A</b>          | <b>Wins</b> | <b>Losses</b> | <b>Seed</b> |
|------------------------|-------------|---------------|-------------|
| 1. Livin' The Dream I  |             |               |             |
| 2. Gardner             |             |               |             |
| 3. CTG Warriors        |             |               |             |
| 4. KC Lightning        |             |               |             |
| <b>Pool B</b>          | <b>Wins</b> | <b>Losses</b> | <b>Seed</b> |
| 5. Livin' The Dream II |             |               |             |
| 6. Stealth - NE        |             |               |             |
| 7. Run N Gun - MO      |             |               |             |
| 8. Bonner Springs      |             |               |             |

| <b>Saturday</b> | <b>BSHS</b>                | <b>PEC</b>                 |
|-----------------|----------------------------|----------------------------|
| 8:00            | -                          | -                          |
| 9:00            | -                          | 1-2                        |
| 10:00           | -                          | 5-8                        |
| 11:00           | -                          | 1-3                        |
| 12:00           | -                          | 5-7                        |
| 1:00            | -                          | 1-4                        |
| 2:00            | -                          | 5-6                        |
| 3:00            | -                          | 2-3                        |
| 4:00            | 6-7                        | -                          |
| 5:00            | 2-4                        | -                          |
| 6:00            | 6-8                        | -                          |
| 7:00            | 3-4                        | -                          |
| 8:00            | 7-8                        | -                          |
| <b>Sunday</b>   | <b>BSHS</b>                | <b>PEC</b>                 |
| 11:00           | -                          | G2                         |
| 12:00           | G1                         |                            |
| 1:00            | -                          | G6                         |
| 2:00            | G5                         |                            |
| 3:00            | -                          | G4 – Championship          |
| 4:00            | G3 – 3 <sup>rd</sup> Place | -                          |
| 5:00            | G7                         | G8 – 1 <sup>st</sup> Place |

# 11<sup>th</sup> – 12<sup>th</sup> Grade Boys

## Bracket A

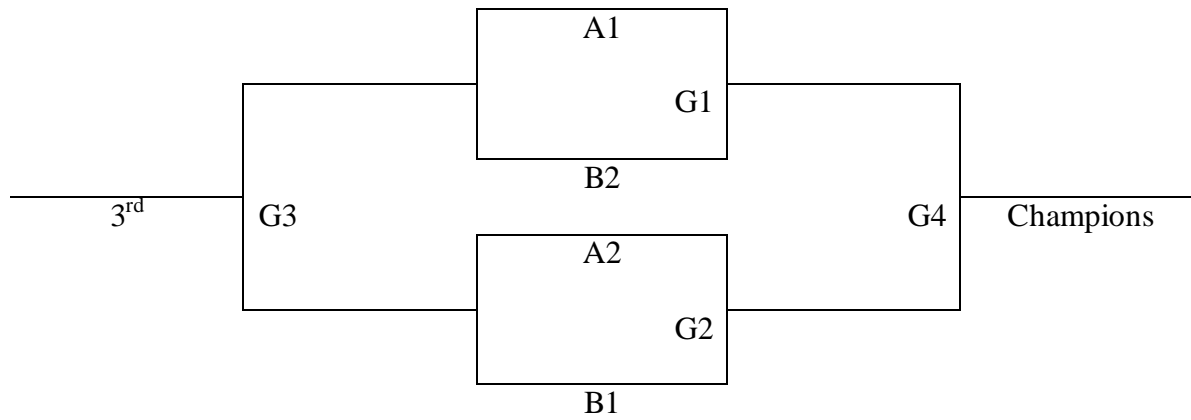

## Bracket B

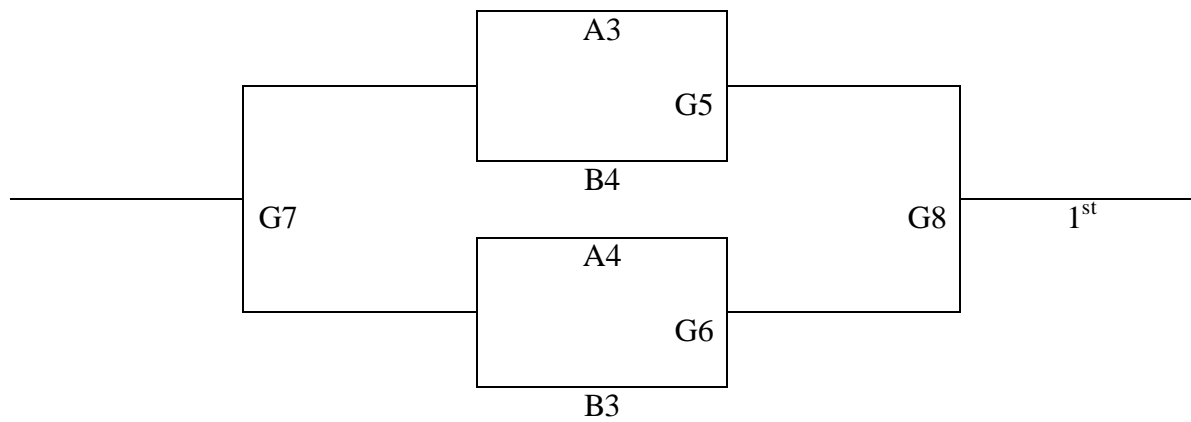

# MAYB

## Summer Tournament Regulations and Guidelines

1. All teams are guaranteed a minimum of 5 scheduled games each weekend. Some teams will play 7 or 8. When possible, teams will be ability grouped after pool play and brackets will be played out.
2. Regulation High School Activities Association rules will be followed with the following exceptions:
  - 20 minute running clock except for last 2 minutes of each half, unless one team is ahead by more than 15 points. If lead falls below 15 points, clock will again stop. In addition, clock will stop on all technical fouls, injuries or timeouts (including officials TO). Clock does not restart until it would in a normal dead ball situation.
  - 4<sup>th</sup>, 5<sup>th</sup>, and 6<sup>th</sup> boys will use girls' size ball. 7<sup>th</sup> grade boys will use the ball size of the state they are playing in. In KS, 7<sup>th</sup> grade boys play with a girls' size ball.
  - 5-minute halftime and 5 minute pre-game warm-up.
  - Game time is forfeit time.
  - We recommend jerseys with numbers on front and back. No number restrictions exist.
  - 4 timeouts per game, no 30-second timeouts.
3. No locker rooms, balls, etc... will be provided by schools.
4. Individual awards for 1<sup>st</sup> and 2<sup>nd</sup> in each age group.  
Team awards for 1<sup>st</sup>. These are minimums!  
We must have at least 4 teams to provide a tournament for an age group and would prefer at least 6. If we do not have these, age groups may be cancelled. MAYB reserves the right to combine age groups without notification.
5. Players may play on only one team within a tournament age group. Player's eligibility will be checked by a current grade card, if requested. Players may play "up" in an older age group. This could mean a player plays in the 8<sup>th</sup> grade tournament and the 9<sup>th</sup>-10<sup>th</sup> grade division. But they can't play on 2 teams in the same 8<sup>th</sup> grade tournament.
6. Each team is required to provide a scorekeeper or clock operator for each game. We have had great success with this. It is harder to yell at your own person, but please do not put kids in this situation. It is unfair to them if adults are yelling at them!
7. All games will be officiated by High School Certified Officials.
8. Inappropriate behavior will not be tolerated!!! A referee may remove players from the game or tournament for inappropriate behavior. We are here for the kids. Do not allow or condone poor sportsmanship. This includes coaches and parents!
9. Referee may stop clock with reason. Intentionally wasting time to shorten the game can be punished with a technical foul. This does not mean a team can't use a delay offense at any time they choose. They simply can't tell players to not line up for free throws or sub 1 player at a time to run the clock.
10. Each tournament site will have a director. Please direct questions to this individual during the weekend.
11. If you need motel lists and playing sites, call The Wichita Sports Commission toll free at 1-800-526-9424.
12. Schedules and brackets will be mailed at least 7-10 days in advance of the tournament.
13. No food or drinks allowed in tournament facilities unless otherwise noted.
14. Tiebreaker procedure is as follows: 1<sup>st</sup> criteria is head to head competition. If a 3-way tie exists and each team has no head to head winner (beat both the other teams) a coin flip is used to determine the first seed. Odd team out wins the first seed. Then tiebreaker procedure reverts to head to head. If teams have all not played each other another form may be used. For a round robin tournament a 3-way tie can be broken by a point differential with a max of plus or minus 15 points per game.
15. Overtimes will be 2 minutes in length with regular clock operation. The clock stops on all dead balls.
16. Each tournament will provide two coaches passes per team.
17. In case of foul weather we will attempt to reschedule games if at all possible. This may mean games are shortened or we play late. Refunds and scheduling at later dates are not possible.
18. All roster changes made after the entry deadline should be given to the tournament director before playing a game at a specific tournament. Grade cards will still be used to determine eligibility. You should have these with you at all times in case of protest. Final eligibility rulings will be made by the area director if weekend conflicts occur. There is no way for the National Office to make these decisions. If you know players will be gone, plan ahead! We want everyone to be able to play, but we do not want teams bringing in players on Sunday because they feel it is the only way to win the tournament.
19. Our first and primary goal remains to give all players maximum court time to improve their game in a competitive setting.