

**9<sup>th</sup>-10<sup>th</sup> Grade Boys  
South Division Gold**

*Games played at Hays H.S. and the Red gym in Kyle, TX.*

**Pool A**

1. TX Ambassadors
2. Triple Threat Tigers White
3. TX Legends
4. SA Runnin Rebels

**W L Pool B**

5. TX Free Style Youth BB
6. Austin Wildcats Silver
7. HC Titans
8. CC Panthers

**W L**

**Friday**      **Red I**      **HHS I**

6:00	1-3	--
7:00	6-7	--
8:00	--	--
9:00	3-4	--

**South Division Gold A**

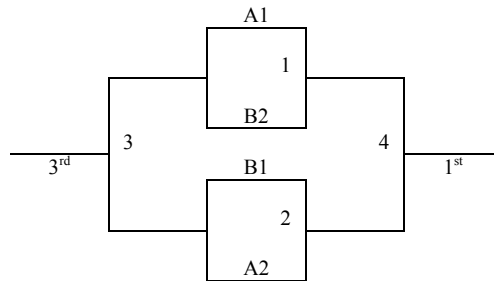

**Sat**

8:00	--	--
9:00	5-8	--
10:00	2-4	--
11:00	--	--
12:00	1-2	--
1:00	--	--
2:00	5-7	--
3:00	6-8	--
4:00	--	--
5:00	--	--
6:00	7-8	1-4
7:00	--	2-3
8:00	--	5-6
9:00	--	--
10:00	--	--

**South Division Gold B**

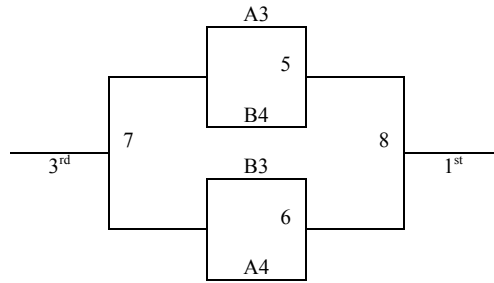

**Sun.**

8:00	G5	--
9:00	G6	--
10:00	G1	--
11:00	G2	--
12:00	G7	--
1:00	G8	--
2:00	G3	G4
3:00	--	--

**9<sup>th</sup>-10<sup>th</sup> Grade Boys  
South Division Silver**

*Games played at Red Gym and Wallace M.S. in Kyle and at TX State U. in San Marcos.*

**Pool A**

1. SV Rangers
2. SA Celtics
3. Elgin Ballers
4. Georgetown Fury Davenport

**W L**

**Pool B**

5. San Marcos Hawks
6. Austin Wildcats Navy I
7. Pflugerville Ballerz
8. SA Wildcats

**W L**

<u>Friday</u>	<u>Red I</u>	<u>Red II</u>	<u>Wal I</u>	<u>Str 1</u>	<u>101A</u>	<u>101B</u>
6:00	--	--	--	--	--	--
7:00	--	--	--	--	--	--
8:00	2-4	--	--	--	--	--
9:00	--	--	--	--	--	--
10:00	--	--	--	7-8	1-2	5-6
<b><u>Sat</u></b>						
8:00	3-4	--	--	--	--	--
9:00	--	5-7	--	--	--	--
10:00	--	--	--	--	--	--
11:00	1-3	--	--	--	--	--
12:00	--	--	--	--	--	--
1:00	6-8	--	2-3	--	--	--
2:00	--	--	1-4	--	--	--
3:00	--	--	--	--	--	--
4:00	5-8	--	--	--	--	--
5:00	6-7	--	--	--	--	--
6:00	--	--	--	--	--	--
7:00	G1	--	--	--	--	--
8:00	G2	--	--	--	--	--
9:00	G5	G6	--	--	--	--
10:00	--	--	--	--	--	--
<b><u>Sun.</u></b>						
8:00	--	--	--	--	--	--
9:00	--	--	--	--	--	--
10:00	--	--	G3	--	--	--
11:00	--	--	G7	--	--	--
12:00	--	--	G8	--	--	--
1:00	--	--	G4	--	--	--
2:00	--	--	--	--	--	--
3:00	--	--	--	--	--	--

**South Division Silver A**

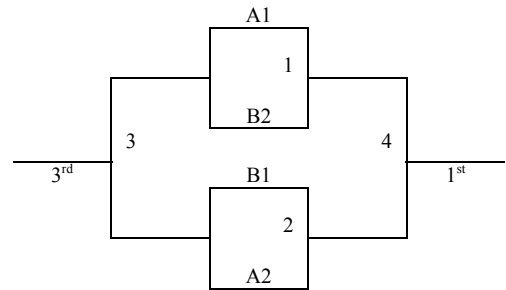

**South Division Silver B**

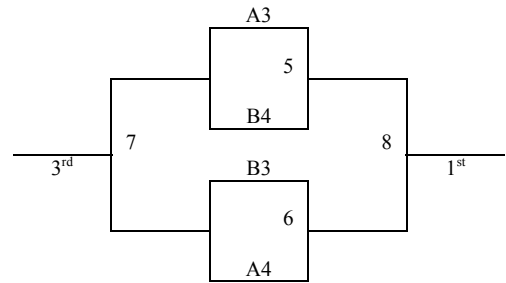

**9<sup>th</sup>-10<sup>th</sup> Grade Boys  
South Division Bronze**

*Games played at Red Gym and Bails Gym in Kyle TX, and at TX State U. in San Marcos.*

**Pool A**

1. Gamma Rays
2. San Marcos Saints
3. Quad City Kings
4. Lightning Hoops

**W L**

**Pool B**

5. Georgetown Fury Hunter
6. Liberty Hill Wildcats
7. Sabinal Outsiders
8. San Marcos Blue Devils

**W L**

**Pool C**

9. SA Magic
10. Austin Wildcats Silver II
11. San Marcos Panthers
12. TX Grey Hounds

**W L**

<u>Friday</u>	<u>Red II</u>	<u>Bails</u>	<u>Str 1</u>	<u>Str 2</u>
6:00	5-6	--	--	--
7:00	10-11	--	--	--
8:00	1-2	--	--	--
9:00	7-8	9-12	--	--
10:00	--	--	--	--
<b>Sat</b>				
8:00	3-4	--	--	--
9:00	--	--	--	--
10:00	5-7	--	--	--
11:00	6-8	--	--	--
12:00	9-11	1-3	--	--
1:00	10-12	2-4	--	--
2:00	5-8	6-7	--	--
3:00	9-10	--	--	--
4:00	11-12	--	--	--
5:00	1-4	2-3	--	--
6:00	--	--	--	--
7:00	G1	G8	--	--
8:00	G2	G9	--	--
9:00	--	--	--	--
10:00	--	--	--	--
<b>Sun.</b>				
8:00	G10	--	--	--
9:00	G11	--	--	--
10:00	G3	--	--	--
11:00	G4	--	--	--
12:00	G12	--	--	--
1:00	G5	--	--	--
2:00	G6	G13	--	--
3:00	--	--	--	--
4:00	--	--	G7	G14

**South Division Bronze A**

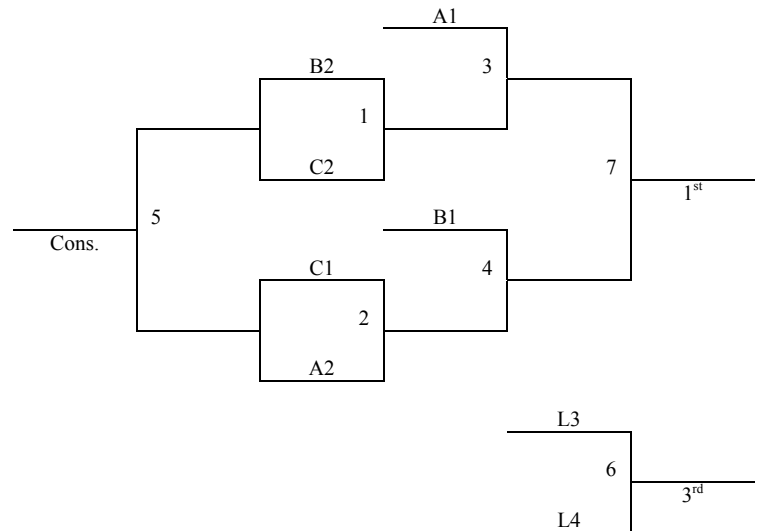

**South Division Bronze B**

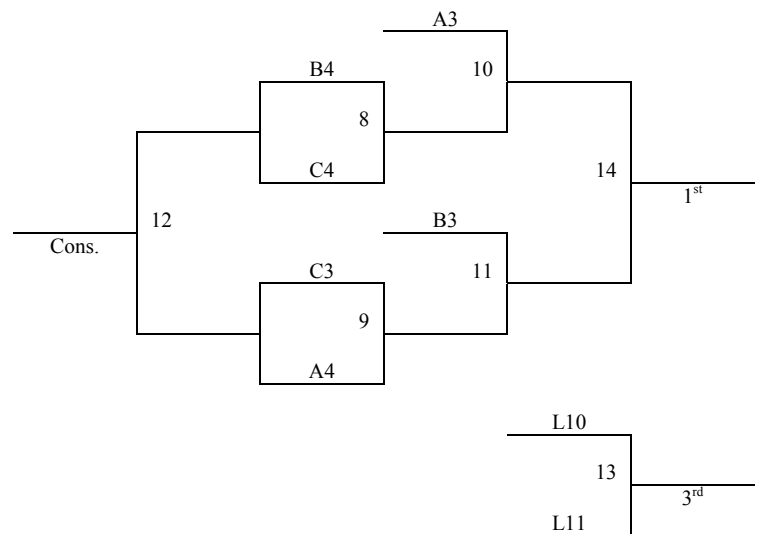

**9<sup>th</sup>-10<sup>th</sup> Grade Girls  
ACC Division Gold  
Games played at TX State U.**

**Pool A**

1. Mansfield Fire
2. S.A. Runnin Rebels
3. Diva Sports
4. Dream Team BB Club Black

**W   L**

**Pool B**

5. S.A. Comets
6. Elgin Ballers
7. West TX Heat
8. Lady Rebels

**W   L**

**Pool C**

9. TKO Lady Dawgs
10. Lady Wolves
11. S.A. Heat
12. San Marcos Lady Saints

**W   L**

<b><u>Friday</u></b>	<b><u>Str 1</u></b>	<b><u>Str 2</u></b>	<b><u>102B</u></b>	<b><u>102A</u></b>
6:00	2-4	--	--	--
7:00	6-8	9-10	--	--
8:00	1-2	11-12	--	--
9:00	5-6	7-8	--	--
10:00	--	--	--	--
<b><u>Sat</u></b>				
8:00	--	--	--	--
9:00	--	--	--	--
10:00	--	5-7	--	--
11:00	--	9-11	--	--
12:00	--	10-12	--	--
1:00	--	1-3	--	--
2:00	--	3-4	--	--
3:00	9-12	10-11	5-8	--
4:00	--	2-3	--	--
5:00	--	6-7	1-4	--
6:00	--	--	--	--
7:00	--	G8	G9	--
8:00	--	G1	--	--
9:00	--	G2	--	--
10:00	--	--	--	--
<b><u>Sun.</u></b>				
8:00	--	--	G10	G3
9:00	--	--	G11	--
10:00	--	--	--	G4
11:00	--	--	G12	--
12:00	--	--	G13	G5
1:00	--	--	--	--
2:00	--	--	G14	G6
3:00	--	G7	--	--
4:00	--	--	--	--

**ACC Gold Tournament A**

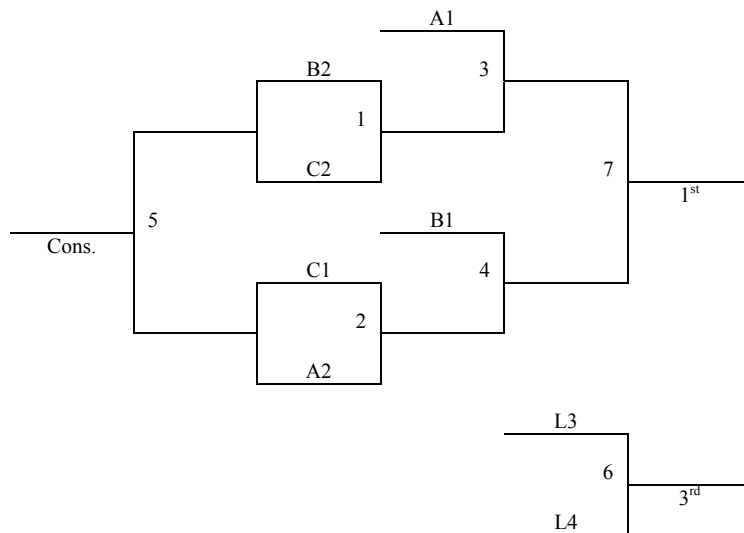

**ACC Gold Tournament B**

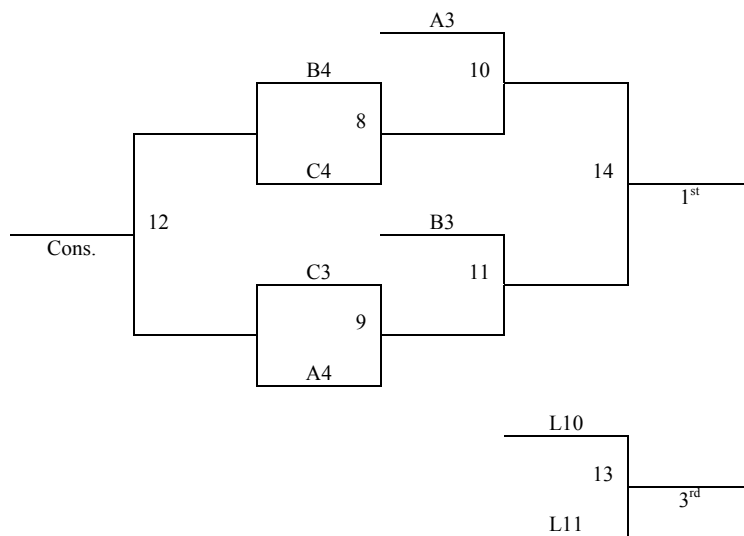



## **REGIONAL CHAMPIONSHIP GYM DIRECTIONS**

### **Hays High School and Red Gym and Bails Gym (North Gym)**

#### **4800 Jack C. Hays Trail /**

From South (heading north) of San Marcos: I-35 north onto exit 213 (Kyle) Turn left and go over the over pass into Kyle. Go pass through 2 stop signs. The third stop sign is route 150. Turn right to the next stop sign (Jack C Hays Trail) and turn right. You will come to Bails Gym (North Gym) first and the next school is Jack C. Hays High School. The Red gyms is between the football stadium and Hays high school.

From the north Exit 217. Go through the stop sign and make a right (landmark: Burger King) Go to Kohlenworth and take a right. It will take you to the high school and junior high school.

### **DIRECTIONS TO WALLACE MIDDLE SCHOOL**

Wallace Middle School – 1500 W. Center St, Kyle, TX 78640 – Heading North on I-35 take exit 213 towards Kyle/FM 150. Merge onto I-35 frontage road. Turn left on E. Center Street. Continue on east Center to Wallace M.S.

Wallace Middle School – 1500 W. Center St, Kyle, TX 78640 – Heading South on I-35 take exit 213 towards Kyle/FM 150. Merge onto I-35 frontage road. Turn right on E. Center Street. Continue on east Center to Wallace M.S.

### **Navarro High School 6450 N State Highway 123, South of Geronimo, TX:**

From the North or South on I-35, get off on exit 204. Turn Left onto TX-123 S / TX-82 Loop S. Continue to follow TX-123 S. You will pass San Marcos High School. (Geronimo is 15 minutes away) End at Navarro High School 6450 N State Highway 123.

### **Texas State University - Strahan Coliseum 601 University Dr.:**

**8 Courts - All numbered courts are at Texas State – Gyms Labeled – SC1, SC2, 101A, 101B, 102A, 102B, 201A, 202B**

From the North or South on I-35, take Exit 206 toward TX-82-Loop / Aquarena Springs Dr. Turn Left onto N I-35. Turn Slight Right onto Aquarena Springs Dr / US-81 BR / TX-82 Loop. Continue to follow TX-82 Loop. End at Strahan Coliseum 601 University Dr, San Marcos, TX 78666, US

## **DIRECTIONS –SAN MARCOS GYMS HILL COUNTRY CHURCH**

From **San Antonio** take 35 to exit 205 in San Marcos. Get in the middle lane and go North on the access road. Pass through all the stop lights and railroad tracks. Get in the right lane and make a right turn on Davis Lane (**Landmark –Dept. of public safety**) Stay on Davis Lane and Hill Country is on the left. The gym is in back of the church.

From **Austin** take exit 206 and take access road to Aquarena rd. Take a left on Aquarena and go under the underpass. Continue to go until you get to River Road (can only make a right or left turn) Take a right on River Road. Drive about 2 minutes and Hill Country is on the right side. (On corner of Davis Lane)

## **SEGUIN GYM DIRECTIONS**

### **GYM DIRECTIONS TO SEGUIN HIGH SCHOOL GOLDIE, WEST GYM AND TOM CRUMP GYMS, BRIESEMEISTER, BARNS AND SAGERT SCHOOLS**

- From IH 10 (West [San Antonio] or East [Houston]) Take Exit 610 ( Hwy TX-123 Bypass going South)
- Turn Right onto Cedar St. ( which will be 2nd light from IH 10 – approx. 1.7 miles)
- **Goldie Harris Complex will be Eastside of football field**
- **Tom Crump Gym will be Westside of football field**
- **West Gym is next to Tom Crump gym**
- From San Marcos (Hwy TX-123) go South on 123
- When you get into Seguin stay on 123 bypass (will be the left-hand lane) do not go onto Business 123 (right-hand lane)
- Turn Right onto Cedar St. ( which will be 2nd light from IH 10 – approx. 1.7 miles)
- From New Braunfels- Go South on Hwy 46 to IH10 and go East
- Take Exit 610 (Hwy TX-123 Bypass) and go South
- Turn right onto Cedar St. ( which will be 2nd light from IH 10 – approx. 1.7 miles)

## **JIM BARNES MIDDLE SCHOOL**

FROM IH 10 (WEST [SAN ANTONIO] OR EAST [HOUSTON]) TAKE EXIT 610 (HWY TX-123 BYPASS GOING SOUTH)

TURN LEFT ON JOE CARRILLO BLVD. (WILL BE APROX. 3 MILES FROM IH10)

WILL GO THROUGH 5 STOP LIGHTS ON THE BYPASS

WILL PASS A WAL-MART ON THE RIGHT-HAND SIDE AND WHEN YOU SEE THE CASA RIO

RESTAURANT AND SOCIAL SECURITY OFFICE ON THE LEFT-HAND SIDE TAKE THE LEFT.

BARNES WILL BE BEHIND THE KOENNECKE ELEMENTARY SCHOOL

**FROM SAN MARCOS** (HWY TX-123) GO SOUTH ON 123

- WHEN YOU GET INTO SEGUIN STAY ON 123 BYPASS (WILL BE THE LEFTHAND

LANE) DO NOT

GO ONTO BUSINESS 123 (RIGHT-HAND LANE)

- TURN LEFT ON JOE CARRILLO BLVD. (WILL BE APROX. 3 MILES FROM IH10)

WILL GO THROUGH 5 STOP LIGHTS ON THE BYPASS

WILL PASS A WAL-MART ON THE RIGHT-HAND SIDE AND WHEN YOU SEE THE CASA RIO

RESTAURANT AND SOCIAL SECURITY OFFICE ON THE LEFT-HAND SIDE TAKE THE LEFT.

BARNES WILL BE BEHIND THE KOENNECKE ELEMENTARY SCHOOL

**FROM NEW BRAUNFELS-** GO SOUTH ON HWY 46 TO IH10 AND GO EAST

- TAKE EXIT 610 (HWY TX-123 BYPASS) AND GO SOUTH

- TURN LEFT ON JOE CARRILLO BLVD. (WILL BE APROX. 3 MILES FROM IH10)

WILL GO THROUGH 5 STOP LIGHTS ON THE BYPASS

WILL PASS A WAL-MART ON THE RIGHT-HAND SIDE AND WHEN YOU SEE THE CASA RIO RESTAURANT AND SOCIAL SECURITY OFFICE ON THE LEFT HAND SIDE TAKE THE LEFT.

BARNES WILL BE BEHIND THE KOENNECKE ELEMENTARY SCHOOL

WILL PASS A WAL-MART ON THE RIGHT-HAND SIDE AND WHEN YOU SEE THE CASA RIO

RESTAURANT AND SOCIAL SECURITY OFFICE ON THE LEFT-HAND SIDE TAKE THE LEFT.

BARNES WILL BE BEHIND THE KOENNECKE ELEMENTARY SCHOOL

**FROM NEW BRAUNFELS-** GO SOUTH ON HWY 46 TO IH10 AND GO EAST

- TAKE EXIT 610 (HWY TX-123 BYPASS) AND GO SOUTH
- TURN LEFT ON JOE CARRILLO BLVD. (WILL BE APROX. 3 MILES FROM IH10)

WILL GO THROUGH 5 STOP LIGHTS ON THE BYPASS

WILL PASS A WAL-MART ON THE RIGHT-HAND SIDE AND WHEN YOU SEE THE CASA RIO RESTAURANT AND SOCIAL SECURITY OFFICE ON THE LEFT HAND SIDE TAKE THE LEFT.

BARNES WILL BE BEHIND THE KOENNECKE ELEMENTARY SCHOOL

## **AJ BRIESEMEISTER MIDDLE SCHOOL**

### **FROM AUSTIN:**

35-S TO SAN MARCOS EXIT SEGUIN 123

ONCE IN SEGUIN – TAKE RIGHT ONTO I-10W (CHILI’S ON LEFT)

EXIT #607 APPROX 2.5 MI.

LEFT AT STOP SIGN TO TX 46-S

LEFT AT STOP LIGHT ONTO TX 46-S

GO TO 2ND STOP LIGHT APPROX. 1 MI. TO WEST COURT

GO RIGHT

AJB- MS ON RIGHT

### **FROM HOUSTON:**

TAKE I-10W TO SEGUIN

EXIT # 607

LEFT AT STOP SIGN TO TX 46-S

LEFT AT STOP LIGHT ONTO TX 46-S

GO TO 2ND STOP LIGHT APPROX. 1 MI. TO WEST COURT

GO RIGHT

AJB- MS ON RIGHT

### **FROM SAN ANTONIO:**

TAKE I-10E TO SEGUIN

EXIT # 607

GO RIGHT ON TX 46-S

GO TO 2ND STOP LIGHT APPROX. 1 MI. TO WEST COURT

GO RIGHT

AJB- MS ON RIGHT

**JOE F SAEGERT 6TH GRADE CENTER**

**FROM AUSTIN:**

35-S TO SAN MARCOS EXIT SEGUIN 123

ONCE IN SEGUIN – TAKE RIGHT ONTO I-10W (CHILI’S ON LEFT)

EXIT #607 APPROX 2.5 MI.

LEFT AT STOP SIGN TO TX 46-S

LEFT AT STOP LIGHT ONTO TX 46-S

GO TO 2ND STOP LIGHT APPROX. 1 MI. TO WEST COURT

TAKE LEFT AT LIGHT- W. COURT

LEFT ON GOODRICH (NEXT TO CHURCH’S CHICKEN)